

HZR Series Dimensions (mm)

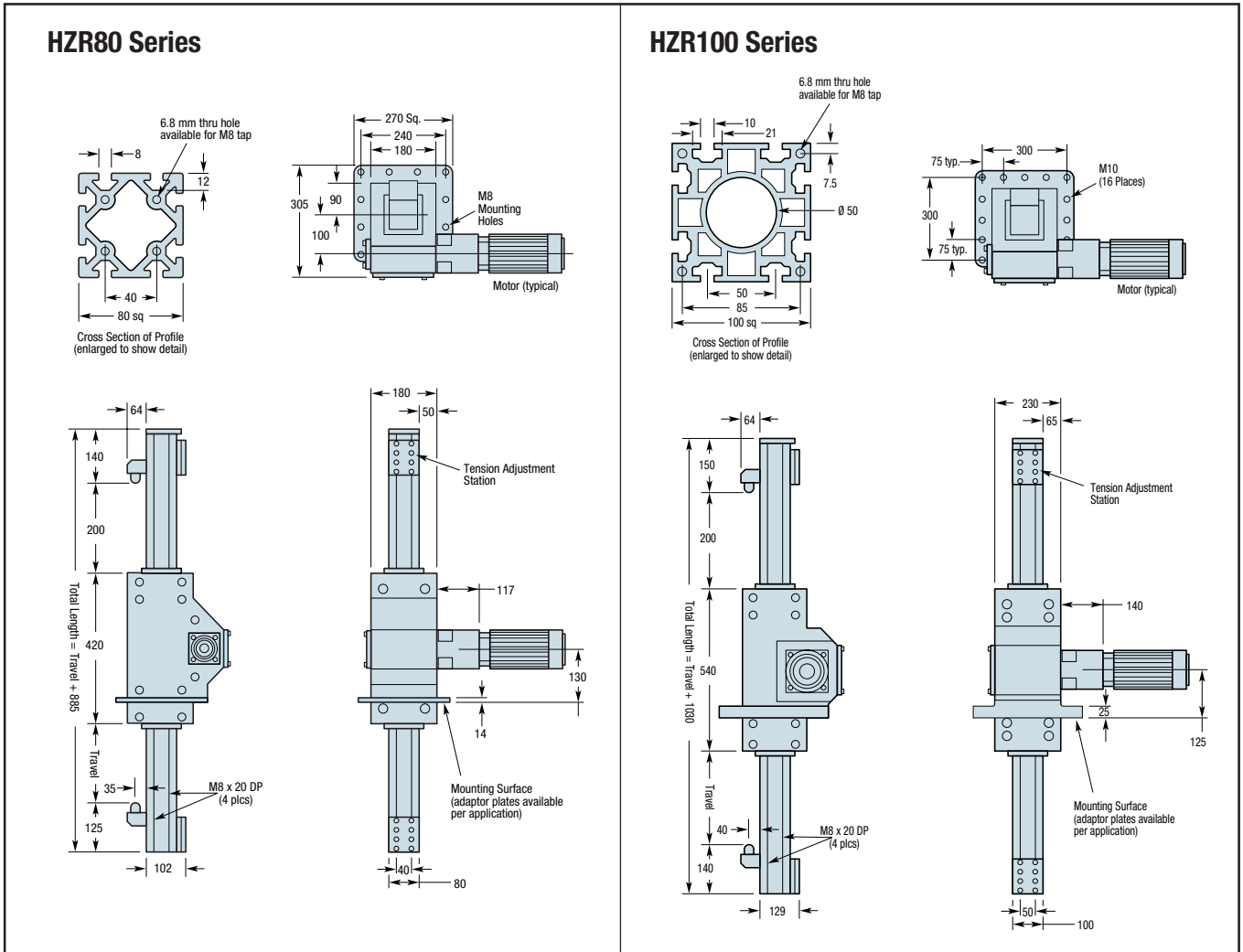

High Speed Automation

HZR80 Series How to Order

Order Example

Model Series

HZR80

Table Travel
XXXX

xxxx (xxxx = (mm))

Mounting Flange Options

- Mounting to HLE100, Center to Center – 360 mm
- Mounting to HLE100, Center to Center – 310 mm
- Mounting to HLE150, Center to Center – 400 mm
- No Mounting Flange

A
B
C
D

Drive Station Interface

- Housing machined to accept 92 mm gearbox
- Housing machined to accept 115 mm gearbox

SP0 (Check Dimensions for Compatibility)
SP1 (Check Dimensions for Compatibility)

Orientation Options

- Gearbox Right
- Gearbox Left

ARO
ALO

Gear Reducer with Motor Mounting Flange

- No Reducer
- Customer Supplied Reducer
- PRN-092 (HDY92/NO92/JO92)
- WPL90 (HDY92/NO92/JO92)
- UTN-092 (JO921/JO922)
- PRN-092 (Universal Flange)
- WPL90 (Universal Flange)
- UTN-092 (Universal Flange)
- PRN-115, Daedal Option (HDY115)
- WPL115 (HDY115)
- PRN-115, Daedal Option (HDY142C6)
- PRN-115, Daedal Option (RS43C)
- PRN-115, Daedal Option (Universal Flange)
- WPL115 (Universal Flange)
- UTN-115, Daedal Option (Universal Flange)

GAA00
GABnn
GZAJnn
GZAKnn
GZAYnn
GZSCnn
GZSDnn
GZSEnn
GZAMnn
GZAPnn
GZAXnn
GZBCnn
GZSFnn
GZSGnn
GZSJnn

*In-line single stage ratios: 3:1, 5:1, 8:1, 10:1
In-line dual stage ratios: 15:1, 25:1
Right angle ratios: 5:1, 8:1, 10:1
Right angle gear reducers mounted parallel to actuator.

Motor Option*

- No Motor M00 N0702FE-NTQN ... M41
- Customer Supplied M01 N0342FE-NTQN ... M42
- HDY92E4-44S M26 J0921GR-NMSN .. M43
- HDY115A6-88S... M28 J0922JR-NMSN ... M44
- HDY115C6-88S .. M29 J0923KR-NMSN ... M45
- RE42CSK10 M36 J0921GE-NMSN .. M46
- HDY70C4-44S M38 J0922JE-NMSN ... M47
- N0704FR-NMSN. M39 J0923KE-NMSN ... M48
- N0342FR-NMSN .. M40

*Zeta stepper motors equipped with 3 meter cable.
Servo motor cables not included (ordered separately).

HZR80 xxxxx A SP1 ALO GZAJnn M43

HZR100 Series How to Order

Order Example

- Model Series**
- Table Travel**
xxxx
- Mounting Flange Options**
Mounting to HLE100, Center to Center – 360 mm
Mounting to HLE150, Center to Center – 400 mm
No Mounting Flange
- Drive Station Interface**
Housing machined to accept 115 mm gearbox
- Orientation Options**
Gearbox Right
- Gear Reducer with Motor Mounting Flange**
No Reducer
- Customer Supplied Reducer
- PRN-115, Daedal Option (HDY115)
- WPL115 (HDY115)
- PRN-115, Daedal Option (Universal Flange)
- WPL-115 (Universal Flange)
- UTN-115, Daedal Option (Universal Flange)
- Motor Option***
No Motor
- Customer Supplied
- HDY115A6-88S
- HDY115C6-88S
- J0921GR-NMSN
- J0922JR-NMSN
- J0923KR-NMSN
- J0921GE-NMSN
- J0922JE-NMSN
- J0923KE-NMSN

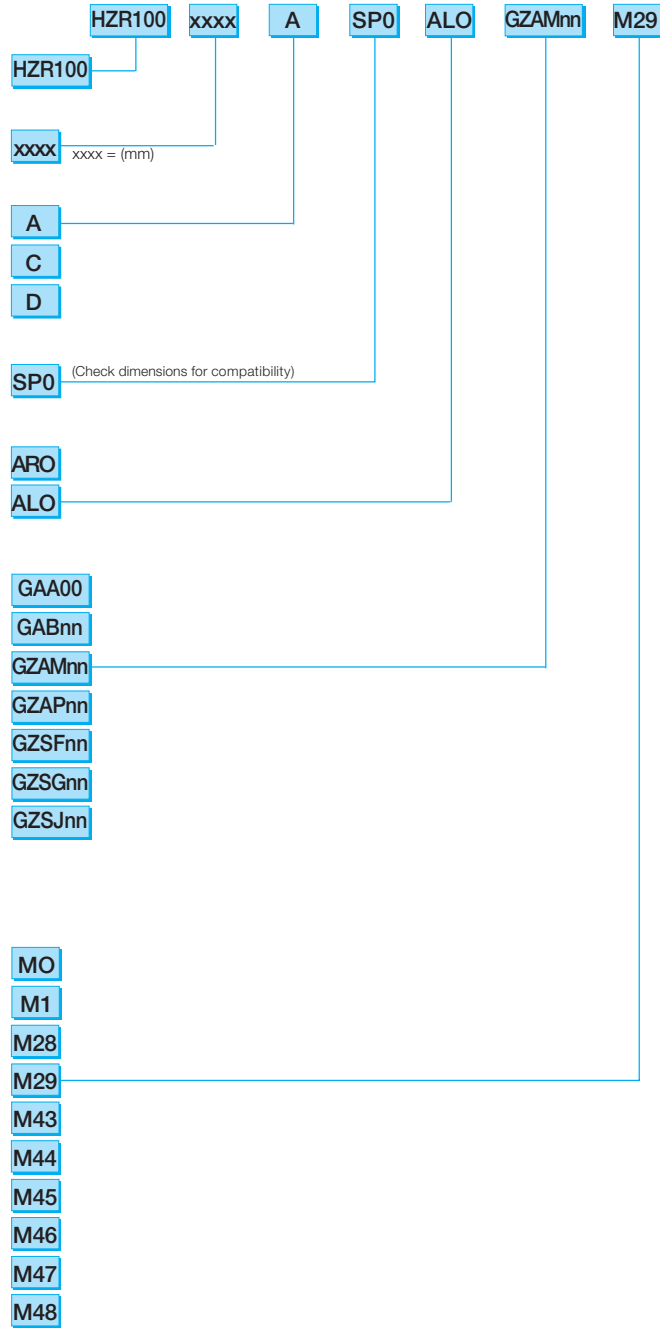

*In-line single stage ratios: 3:1, 5:1, 8:1, 10:1
In-line dual stage ratios: 15:1, 25:1
Right angle ratios: 5:1, 8:1, 10:1
Right angle gear reducers mounted parallel to actuator.

*Zeta stepper motors equipped with 3 meter cable.
Servo motor cables not included (ordered separately).

High Speed Automation